

# DATE STAMP FOR DIE CASTING MOULDS

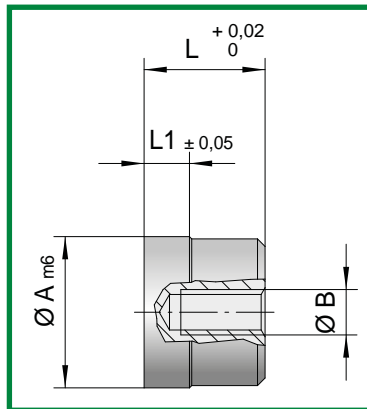

## COMPLETE DATE STAMP

A	B	L	L1
5	M3	10	4
6	M4	10	4
8	M4	10	4
10	M5	12	5
12	M6	14	5
16	M6	14	6
20	M6	16	6

Mat.: AISI 420B

Hardness: 46÷48 HRC



### ORDER CODE

DAP-5N

DAP-6N

DAP-8N

DAP-10N

DAP-12N

DAP-16N

DAP-20N

### ORDER CODE

DAP-5A

DAP-6A

DAP-8A

DAP-10A

DAP-12A

DAP-16A

DAP-20A