



# SWAP® VALVE

## Compressed Air Cooling Water Purge

U.S. Patent No.  
6,471,503



Two-inch  
SPV16-A-A

One-inch  
SPV8-A-A

### General Description

The Smartflow® SWAP® Valve supplies cooling water to the mold during processing. Secondly, it supplies air to purge the water from the mold, cooling lines, Supply and Return manifolds prior to tool change. And, it provides a manual vent to release built-up air pressure within the cooling water loop, after purging.

An included check valve should be installed in the return line downstream from the Return manifold to prevent backflow to the mold.

Tubing may be connected to the manual vent-drain port so any residual water after the purge cycle can be drained into a container or drain.

An optional spring-loaded, locking pin is available for molders who require two-hand operation. This prevents accidental valve handle movement.

### Typical Hook-Up Schematic

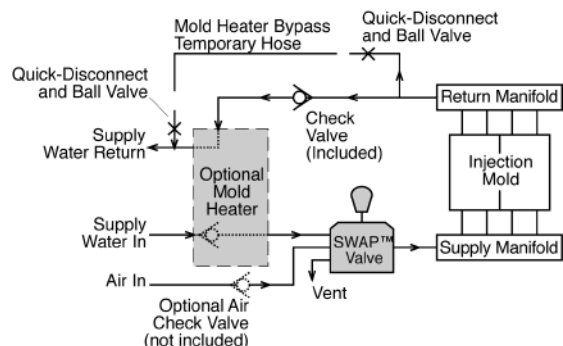

### Application

The SWAP® Valve is well-suited for cooling water Supply lines up to 2-inch NPT on frequently changed injection molding tools. It is permissible to adapt 3/4, 1 1/4, and 1 1/2-inch line sizes providing adequate cooling water flow can be achieved.

Typical mounting is on the press frame or the safety door frame. Mounting on any suitable surface, such as a platen, mold or manifold stand is acceptable.

### Operation

For Normal Processing:	Select <b>WATER</b> . Cooling Water is available to the Supply manifold. Purge Air is blocked.
To Evacuate Cooling Water:	Select <b>PURGE</b> . Purge Air is available to the Supply manifold. Cooling Water is blocked.
To Bleed-Off Trapped Pressure and Drain Residual Water:	Select <b>VENT</b> Press Manual Vent-Drain Valve. Purge Air is blocked. Cooling Water is blocked.

### Molder Benefits

- ◆ **Timesaving:** Saves 15-20 minutes of unproductive tool change time by eliminating the tasks of draining multiple Supply and Return hoses plus cleaning-up water spills.
- ◆ **Tool Condition:** Protects tools from corrosion build-up during downtime and storage by evacuating water quickly and thoroughly.
- ◆ **Supply Line ID:** Permits fast identification of Supply lines by noting which manifold is connected to the SWAP® Valve.
- ◆ **Water Shut-Off:** SWAP® Valve shuts-off Supply water conveniently near the machine control, rather than with conventional ball valves on the water drops/risers or Supply manifold, typically located at the opposite side of the press.
- ◆ **Full Port Design:** Permits maximum cooling water flow at minimum pressure drop.
- ◆ **Safety-Housekeeping:** Eliminates root cause of accidents around the press by keeping personnel and floors dry.
- ◆ **Optional Positive Lock:** Eliminates accidental movement of valve selector handle.



# SWAP<sup>®</sup> VALVE

## Pneumatic Mold Cooling Water Purge

### Specifications

Maximum Pressure .....150 psi (10.3 bar)  
 Maximum Operating Temperature.....250°F (121°C)  
 Normal Working Air Pressure.....80 to 100 psi  
 (integral snubber prevents hose “whip” during purging)  
 Pressure Drop Across Purge Valve.....1 psi at 50gpm

### Wetted Parts

Body and Valve Disc .....T6061 Aluminum  
 PTFE Impregnated  
 Hard Anodize Coating  
 O-Rings .....EPDM  
 Check Valve .....Brass

### Model Numbers (Check Valve included)

Model	Thread Size	SWAP Model	Weight
SPV8-A-A	1"NPT	Standard	3kg 7lbs
SPV8-L-A	1"NPT	With Locking Pin	
SPV8B-A-A	1"BSPP	Standard	
SPV8B-L-A	1"BSPP	With Locking Pin	
SPV16-A-A	2"NPT	Standard	4.5kg 10.5lbs
SPV16-L-A	2"NPT	With Locking Pin	
SPV16B-A-A	2"BSPP	Standard	
SPV16B-L-A	2"BSPP	With Locking Pin	

(Check Valve not included)

SPV8B-A-AN	1"BSPP	Standard	3kg 7lbs
SPV8B-L-AN	1"BSPP	With Locking Pin	
SPV16B-A-AN	2"BSPP	Standard	4.5kg 10.5lbs
SPV16B-L-AN	2"BSPP	With Locking Pin	

### Regarding Galvanic Corrosion

It is strongly recommended that a Dielectric Fitting (see Accessories below) is purchased for use with this valve when copper or brass piping is present in the water circulating lines. Galvanic corrosion can occur in the presence of:

- more noble metals
- electrolytic connection
- water treatment with copper or bleach
- elevated water temperatures.

A dielectric fitting breaks the electrical connection between dissimilar metals helping reduce the incidence of galvanic corrosion.

### Accessories

Part Number	Description
DN-8	Dielectric Fitting 1"NPT
DN-8B	Dielectric Fitting 1"BSPT
DN-16	Dielectric Fitting 2"NPT
DN-16B	Dielectric Fitting 2"BSPT
PVOSET-100A	Replacement O-Ring Set 1"
PVOSET-200A	Replacement O-Ring Set 2"
PVCV-100*	Brass Check Valve 1"NPT
PVCV-200*	Brass Check Valve 2"NPT
PVCV-100B*	Brass Check Valve 1"BSPP
PVCV-200B*	Brass Check Valve 2"BSPP
PVCV-3	Air Check Valve 3/8"NPT

\* Included with new SWAP Valve

### Dimensions

