



Intelligent Hydraulic Cylinders

V220CC



**Long Stroke Block Cylinder With Or Without
Magnetic Switches Option, 220 Bar**

*Cilindri oleodinamici compatti a corsa lunga con
o senza sensori magnetici di fine corsa, 220 bar*

Cat0802.GB+IT

www.vegacylinder.com

Order compilation symbols - Simbologia per redigere un ordine

V220CC

Cylinder MODEL V220CC
Modello cilindro V220CC

CC

Cylinder BORE (ØX)
ALESAGGIO cilindro
- P. C3

032	040	050
063	080	100

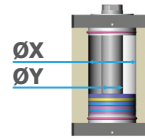

ØX = Bore Alesaggio
ØY = Rod Stelo

Clamping STYLE
Fissaggio
- P. C5-9

C Longitudinal through holes Fori passanti longitudinali	B Front+Rear threaded holes Fori filettati ant + post	E Key way Chiavetta
F Front flange - Flangia anteriore	G Rear flange - Flangia posteriore	

Oil Ports TYPE
TIPO di orifizi
- P. C8-9

- G** BSP Thread - Filetto BSP
- N** NPT Thread - Filetto NPT
- O** Manifold with o-rings - Integrati con o-rings

Oil Ports POSITION
POSIZIONE orifizi
- P. C8-9

- H** Left side (threaded) - Sinistra (filettati)
- M** Right side (threaded) - Destra (filettati)
- F** Front side (o-rings) - Frontale (o-rings)
- R** Rear side (o-rings) - Posteriore (o-rings)
- E** Bottom side (o-rings and threaded) - Lato inferiore (o-rings e filettati)

Rod end TYPE
Estremità STELO
- P. C10

- G** Female Metric thread - Filetto femmina Metrico
- I** Female UNF thread - Filetto femmina UNF
- A** Male Metric thread - Filetto maschio Metrico
- H** Male UNF thread - Filetto maschio UNF
- F** Floating joint - Testa a martello

CC 050 E G H G M 250,0 X0099,0

Accessories Accessori

- M** Magnetic switches preset
Predisposto ai sensori magnetici
- N** Without magnetic switches preset
Non predisposto ai sensori magnetici
- W** Body without switches key
Corpo senza cava sensori

Cylinder VERSION
VERSIONE Cilindro
- P. C11

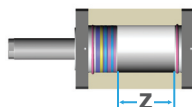

Cylinder STROKE (Z)
CORSA cilindro (Z)
- P. C4

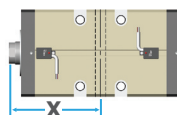

X QUOTE, only for "E" clamping
QUOTA X, solo per fissaggio "E"
- P. C5

- MTA** Male Thread - Filetto Maschio
- MFA** Floating Joint - Testa a martello
- DFA** Floating Joint with Female - Testa a martello con femmina

Rod Accessories
Accessori Stelo
- P. C12

MTA20x250

MSU4

MSU4 Magnetic Switches
Sensori Magnetici
- P. C11



Pay attention to the BEST PRICE cylinders! By selecting all the "BEST PRICE" options - bore, stroke, mounting, rod and oil ports - you save up to 30% on cylinder price and you will have stock cylinders in Italy, China and other locations. Best price and service with same quality!

Attenzione ai cilindri BEST PRICE! Selezionando tutte le opzioni "BEST PRICE" - alesaggio, corsa, fissaggio, orifizi e stelo - potrete configurare cilindri con prezzo ridotto fino al 30%, disponibili a magazzino in Italia, Cina ed alcune altre località nel mondo. Miglior prezzo e miglior servizio con uguale qualità!

Product presentation and general features

Presentazione del prodotto e caratteristiche generali

The V220CC cylinders have been specially designed for being extremely compact and for applying the integrated end stroke MAGNETIC SWITCHES. They are the complement to the V250CE for strokes higher than 50 mm. and represent the model which permits the highest customization following the customers exigencies for special options as: clamping style, rod end, oil delivery, etc. Available bores: from 32 mm. to 100 mm. Strokes 50 to 500 mm. (see details at page C4). These cylinders are ideal for displacing ejector plates on any plastic injection molds or any long stroke slides which are inside or partially inside the mold.

I cilindri serie V220CC sono concepiti per essere estremamente compatti e per essere dotati di SENSORI MAGNETICI di fine corsa. Rappresentano l'alternativa al V250CE per le corse superiori a 50 mm. Inoltre, grazie al tipo di costruzione, permettono numerose personalizzazioni ed esecuzioni a disegno del cliente quali fissaggio, estremità stelo, alimentazione olio, ecc. Alesaggi disponibili da 32 a 100 mm. Corse da 50 a 500 mm. (vedere dettagli a pagina C4). Questi cilindri sono ideali su stampi per iniezione plastica per movimentazione piastre d'estrazione o carrelli con corse lunghe inserite all'interno, o parzialmente all'interno dello stampo.

Steel rod seals-cartridge with PTFE+ Bronze seals with FKM O-ring. Guide rings are in polyester or phenolic resin for a high resistance and a long life. This solution with separate seals lodging from the body simplifies the seals replacement.

Cartuccia porta guarnizioni per lo stelo in acciaio, con guarnizioni in PTFE+Bronzo ed O-ring in FKM. Fasce di guida in Poliestere o resina fenolica per un'alta resistenza allo schiacciamento ed una lunga durata. La soluzione della cartuccia separata facilita la sostituzione delle guarnizioni.

Chrome-plated steel rod, hardened and polished. Thickness of chromium plating 20 µm and surface finish 0,4 µm Ra, for a longer durability of the seals.

Stelo in acciaio bonificato, cromato e lucidato. Spessore cromatura 20 µm e finitura superficiale 0,4 µm Ra, che prolunga notevolmente la durata delle guarnizioni.

Special aluminum alloy body for high pressure resistance and adapt for the magnetic switches. "Non magnetic" version can be built with steel body.

Corpo in lega speciale d'alluminio per un'elevata resistenza alla pressione ed adatto all'uso dei sensori magnetici. Nella versione "non magnetica" il corpo può essere costruito in acciaio.

Special aluminum alloy piston, in two segments with syntherized magnet ring and PTFE+ Bronze seals with FKM Oring. Guide rings are in polyester or phenolic resin for a high resistance and a long life. "Non magnetic" version can be built with steel piston.

Pistone in lega speciale d'alluminio in due settori con inserito anello magnetico sinterizzato. Guarnizioni in PTFE+Bronzo ed O-ring in FKM. Fasce di guida in Poliestere o resina fenolica per un'alta resistenza allo schiacciamento ed una lunga durata. Nella versione "non magnetica" il pistone può essere costruito in acciaio.

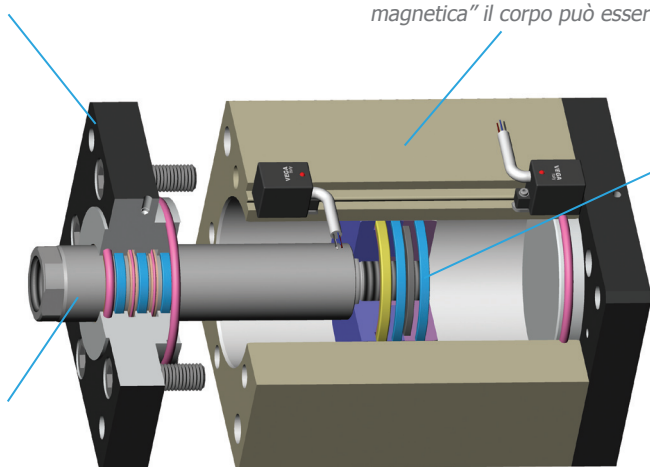

Cylinder ACCESSORIES - ACCESSORI cilindro

Unidirectional flow controller to regulate the speed of the piston and steel hydraulic pipe fittings for flow controller (see accessories catalogue).

Regolatore di flusso unidirezionale per regolare la velocità del pistone e nippoli di connessione accessori oleodinamici (vedi catalogo accessori).

Rod end accessories: male thread with locknut; floating joint with locknut and floating joint with female of the floating joint, for increasing the connection options between rod and slide.

Accessori per lo stelo: terminale maschio con controdado, testa a martello con controdado e testa a martello con femmina della testa a martello, per offrire ulteriori opzioni di connessione fra stelo ed applicazione.

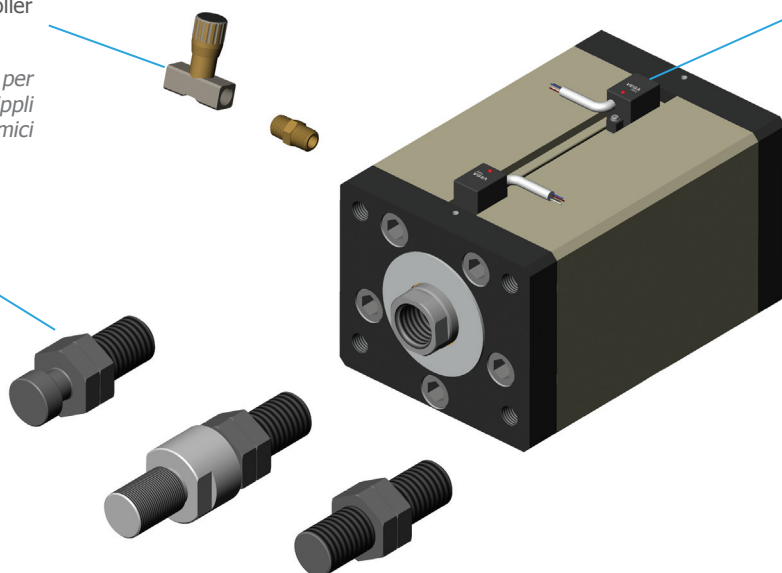

End stroke magnetic switches, in option (the picture shows the external box. Switches are inside the cylinder - see page C11).

Sensori magnetici di fine corsa, opzionali (l'immagine mostra solo la parte visibile all'esterno del cilindro. I sensori sono inseriti nel cilindro. - vedere pagina C11)

TECHNICAL AND WORKING CHARACTERISTICS Chart

Tabella CARATTERISTICHE TECNICHE E DI FUNZIONAMENTO

V220CC

ØX	Maximum Working PRESSURE in Bar - PSI PRESSIONE max. di esercizio in Bar - PSI				Maximum Nominal delivery (pushing) L/min Portata Max. Nominale (in spinta) L/min		Maximum piston speed m/s Velocità max. pistone m/s	Maximum working temperature Temperatura max. esercizio	
	MAGNETIC Cylinder Cilindro MAGNETICO		NON magnetic Cylinder Cilindro NON magnetico		MAGNETIC cylinder Cilindro MAGNETICO	NON magnetic Cyl. Cil. NON magnetico		MAGNETIC Cylinder Cilindro MAGNETICO	NON magnetic Cylinder Cil. NON magnetico
	O-rings oil delivery Alimentaz. O-rings	Threaded oil delivery Orifizi filettati	O-rings oil delivery Alimentaz. O-rings	Threaded oil delivery Orifizi filettati					
32	160 - 2320	220 - 3190	160 - 2320	220 - 3190	4	4	0,1	80°C - 176° F	100°C - 212°F
40	140 - 2030	220 - 3190	140 - 2030	220 - 3190	7	7	0,1		
50	140 - 2030	200 - 2900	140 - 2030	200 - 2900	10	10	0,1		
63	120 - 1740	180 - 2610	120 - 1740	180 - 2610	15	15	0,1		
80	120 - 1740	180 - 2610	120 - 1740	180 - 2610	30	30	0,1		
100	120 - 1740	160 - 2320	120 - 1740	160 - 2320	45	45	0,1		

➔ Choice of **BORE size and STROKE** - Determinazione di **ALESAGGIO e CORSA**

Table THRUST and TRACTION FORCE in Kg.
Tabella FORZE IN SPINTA e TRAZIONE in Kg.



ØX	ØY	80 bar-1160 PSI		100 bar-1450 PSI		125 bar-1812 PSI		160 bar-2320 PSI		200 bar-2900 PSI	
		Thrust	Traction	Thrust	Traction	Thrust	Traction	Thrust	Traction	Thrust	Traction
		Spinta	Trazione	Spinta	Trazione	Spinta	Trazione	Spinta	Trazione	Spinta	Trazione
032	22	643	440	804	550	1005	688	1286	880	1608	1100
040	22	1005	701	1256	876	1570	1095	2010	1402	2512	1752
050	28	1570	1078	1963	1347	2453	1684	3140	2155	3925	2694
063	28	2493	1679	3116	2099	3895	2623	4985	3358	6231	4197
080	36	4019	3205	5024	4007	6280	5008	8038	6411	10048	8013
100	45	6280	5008	7850	6260	9813	7825	12560	10017	-	-

Example of order code:
Esempio di codice ordine:

CC 050 [] [] [] [] [] [] [] [] 250,0 []

STANDARD STROKES Table in mm.
Tabella CORSE STANDARD in mm.

Z ØX	080,0	100,0	150,0	200,0	250,0	300,0
32					#	#
40					#	#
50						#
63						#
80						
100						

 BEST PRICE STROKES - CORSE BEST PRICE
 STANDARD STROKES - CORSE STANDARD
 SPECIAL STROKES - CORSE SPECIALI



NOTE: FOR STROKES SHORTER THAN 80 mm. WE SUGGEST TO CHOOSE MOD. V250CE or V450CM CYLINDERS which are more compact and cheaper.
 NOTA: PER CORSE INFERIORI A 80 mm: SUGGERIAMO DI SCEGLIERE I CILINDRI MODELLO V250CE o V450CM che sono più compatti ed economici.

#: Not available with longitudinal through holes (code "C") or with manifold oil delivery (code "OE", "OR" or "OF")
 #: Non disponibile con fissaggio fori longitudinali passanti (codice "C") o con orifizi integrati con o-rings (codici: "OE", "OR" o "OF").

ØX	MINIMUM STROKE in mm. CORSA MINIMA in mm.		MAXIMUM STROKE in mm. CORSA MASSIMA in mm.		
	With "E" code clamping + threaded oil ports Con fissaggio codice "E" + orifizi filettati	With all other clampings and oil ports Con tutti gli altri fissaggi e orifizi	All clampings with "OF", "OR" and "OE" oil ports codes - with o-rings Per tutti i fissaggi con codice orifizi "OF", "OR" e "OE" (con o-rings)	Clamping code "C" with all oil ports types Per fissaggio "C" con tutti i tipi di orifizi	With all other clampings and oil ports Con tutti gli altri fissaggi e orifizi
32	65	65	200	200	300
40	65	65	200	200	350
50	65	65	250	250	400
63	75	65	250	250	450
80	90	65	300	300	500
100	90	65	300	300	500

Note: Stroke tolerance: -0/+0,5 mm. Special strokes can be manufactured. Would you please contact our sales service.
 Note: Tolleranza sulla corsa: -0/+0,5 mm. Corse speciali sono fornibili a richiesta. Contattare il nostro ufficio vendite.

ØX = Bore Alesaggio ØY = Rod Stelo Z = Stroke Corsa

Choice of **CLAMPING style** - Determinazione del **FISSAGGIO**

Example of order code:
Esempio di codice ordine:

CC 050 **E** 250,0 **X0099,0**

E Lateral through holes with key-way
Fori passanti laterali con chiavetta

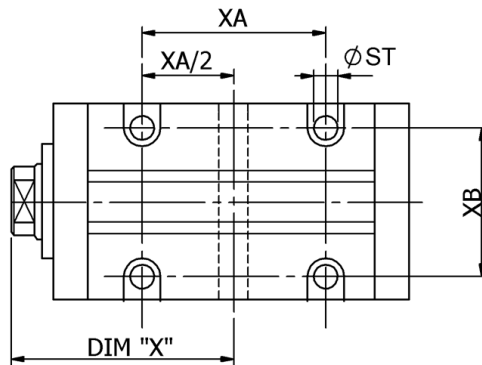
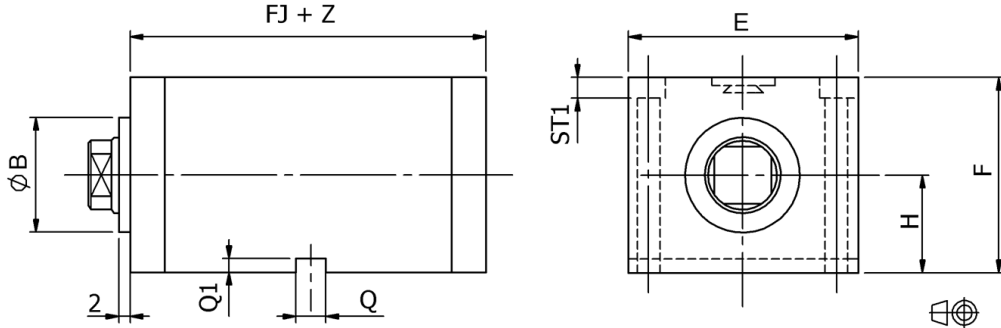
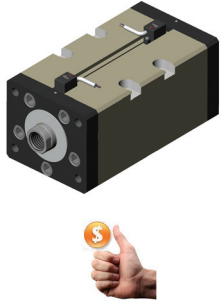

DIM "X" (TO BE SPECIFIED) SEE TABLE BELOW
DIM "X" (DA SPECIFICARE) VEDI TABELLA

NOTE: The key-way position as well as the fixing holes - which remain at same distance between each other as indicated with the quote XA - are under customer preference and must be indicated by the "X" quote. The table here above shows the minimum, maximum acceptable and the BEST PRICE options.

NOTA: La posizione della chiavetta di fissaggio, con conseguente posizione dei fori di fissaggio - che restano comunque alla stessa distanza fra loro come indica la quota XA - è a scelta del cliente e va indicata con la quota "X". La tabella sotto ne indica quella minima, massima e BEST PRICE.

X ,

DIMENSION "X" mm. - QUOTA "X" in mm.						
If used as an ordering code it must be specified with three numbers before the comma and one decimal position Se usata come codice ordine deve essere specificata con tre numeri interi ed un decimale.						
Dimensions "X" for threaded oil delivery version Quota "X" per versione con orifizi filettati				Dimensions "X" for manifold oil delivery version Quota "X" per versione con orifizi con o-rings		
ØX	MIN - MIN.	MAX + Stroke MAX + Corsa	BEST PRICE X BEST PRICE X	MIN - MIN.	MAX + Stroke MAX + Corsa	BEST PRICE X BEST PRICE X
32	0078,0	0028,0	-	0068,0	0038,0	-
40	0087,0	0037,0	0087,0	0073,0	0043,0	0087,0
50	0099,0	0034,0	0099,0	0086,0	0046,0	0099,0
63	0107,0	0032,0	0107,0	0091,0	0051,0	0107,0
80	0121,0	0031,0	0121,0	0108,0	0043,0	0121,0
100	0131,0	0041,0	-	0118,0	0053,0	-

ØX	ØY	ØB	E	F	FJ+	H	Q	Q1	ST	ST1	XA	XB
32	18	32	75	65	86	32,5	10	5	10,5	11	50	58
40	22	40	85	75	98,5	37,5	12	5	10,5	11	60	65
50	28	50	100	87	106,5	43,5	15	5	12,5	13	70	75
63	36	63	120	102	108,5	52	15	5	12,5	13	70	90
80	36	70	150	125	122	65	20	5	17	17	80	110
100	45	90	170	145	130	75	20	5	17	17	80	130

ØX = Bore Alesaggio ØY = Rod Stelo Z = Stroke Corsa

V220CC

Choice of **CLAMPING style** - Determinazione del **FISSAGGIO**

Example of order code:
Esempio di codice ordine:

CC 050 **B** 250,0

B

Front and rear threaded holes
Fori filettati anteriori e posteriori

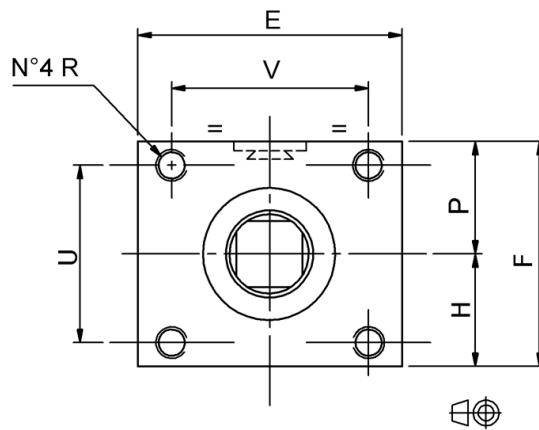
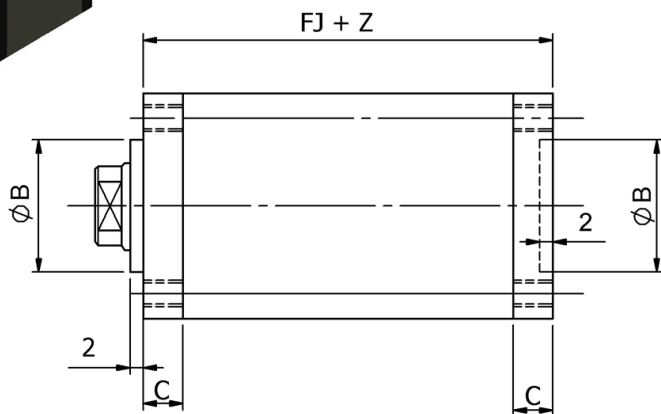
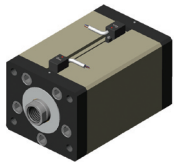

C

Longitudinal through holes
Fori passanti longitudinali

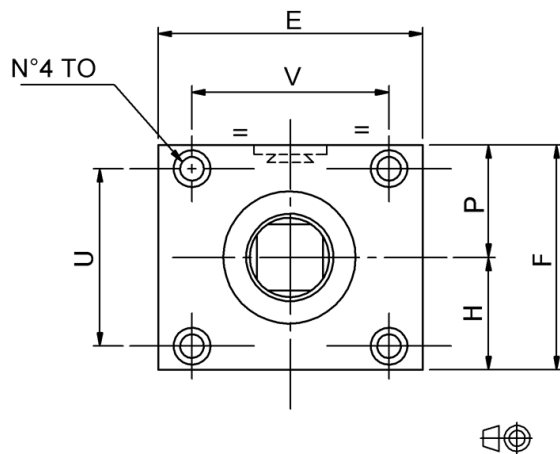
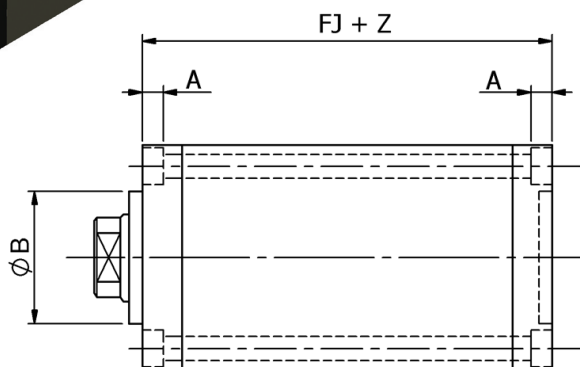
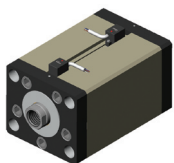

$\varnothing X$	$\varnothing Y$	A	$\varnothing B$	C	E	F	FJ+	H	P	R	TO	U	V
32	18	9	32	15	75	65	86	32,5	32,5	M8x1,25	9	48	58
40	22	10,5	40	15	85	75	98,5	37,5	37,5	M10x1,5	11	55	65
50	28	13	50	19	100	87	106,5	43,5	43,5	M12x1,75	13,5	63	76
63	36	13	63	20	120	102	108,5	52	50	M12x1,75	13,5	78	96
80	36	17	70	27	150	125	122	65	60	M16x2	17,5	90	120
100	45	17	90	27	170	145	130	75	70	M16x2	17,5	104	134

$\varnothing X$ = Bore Alesaggio $\varnothing Y$ = Rod Stelo Z = Stroke Corsa

➔ Choice of **CLAMPING style** - Determinazione del **FISSAGGIO**

Example of order code:
Esempio di codice ordine:

CC 050 **F** 250,0

F Front flange
Flangia anteriore

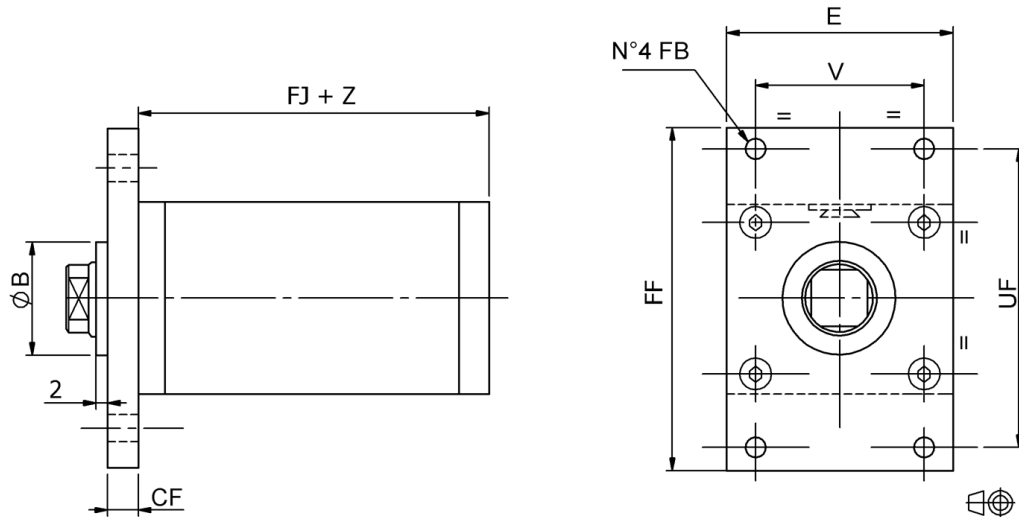
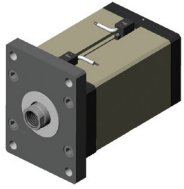

G Rear flange
Flangia posteriore

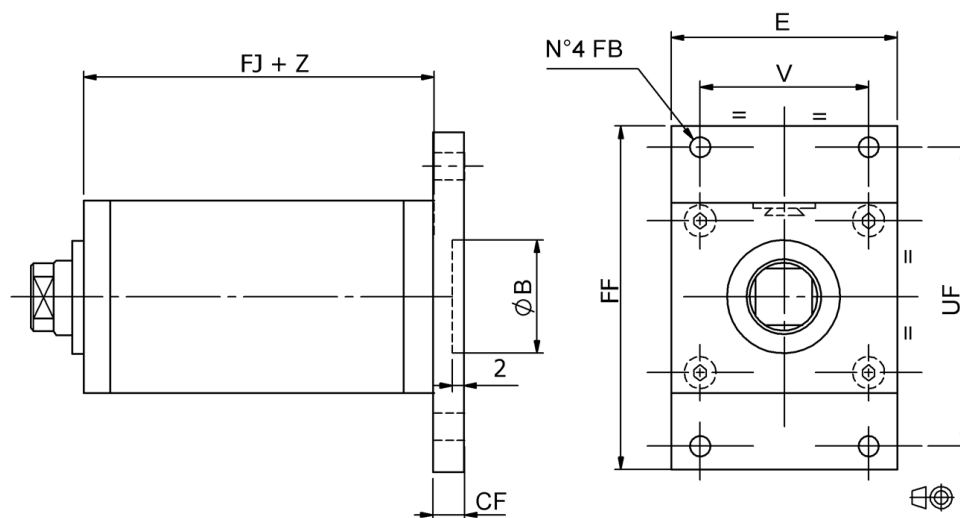
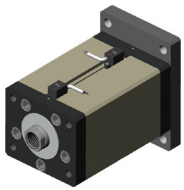

ØX	ØY	ØB	CF	E	FB	FF	FJ+	UF	V
32	18	32	15	75	11	120	86	94	58
40	22	40	15	85	11	130	98,5	104	65
50	28	50	20	100	13	150	106,5	120	76
63	36	63	20	120	13	165	108,5	136	96
80	36	70	27	150	17,5	210	122	170	120
100	45	90	27	170	17,5	230	130	190	134

ØX = Bore Alesaggio ØY = Rod Stelo Z = Stroke Corsa

V220CC

➔ Choice of **OIL PORTS** type and position
 Determinazione degli **ORIFIZI** tipo e posizione

Example of order code: CC 050 C G H 250,0
 Esempio di codice ordine:

V220CC

G
N

BSP Threaded Oil Delivery
Orifizi filettati BSP (Gas)
NPT threaded oil delivery
Orifizi filettati NPT

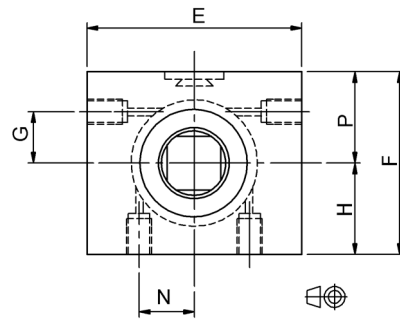
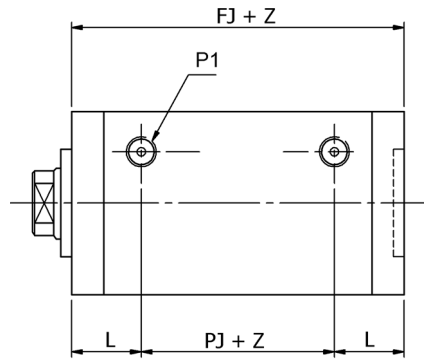

H

Left or right or bottom side
Lato sinistro, destro o sotto

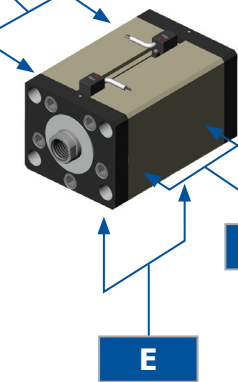

O

Manifold oil delivery
Integrati con O-Rings

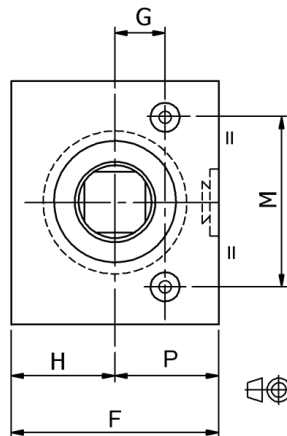
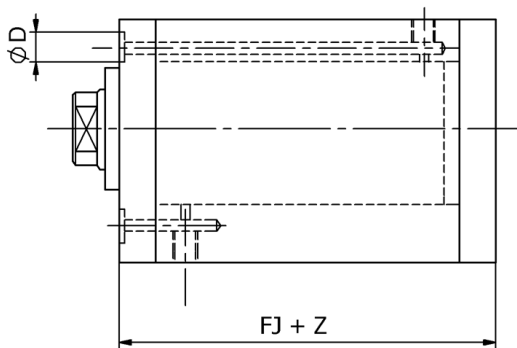

F

Front side
 only for clamping B, C and G
Lato Frontale
 solo per fissaggio B, C e G

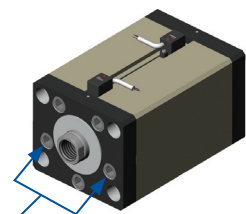

NOTES FOR MANIFOLD OIL DELIVERY: Max. bore of the oil delivery hole in the mold: 4,5 mm. for cylinder bore 32 to 50; 6 mm. for other cyl. bore. Max. eccentricity 0,5 mm. FKM O-Rings are included.
 NOTE PER ORIFIZI CON O-RINGS: Diametro max. del foro di alimentazione da eseguire nello stampo: 4,5 mm. per alesaggio cilindro da 32 a 50; 6 mm. per gli altri. Eccentricità max. 0,5 mm. Gli O-Ring in FKM sono inclusi nella fornitura.

ØX	ØY	ØB	ØD	E	F	FJ+	G	H	L	M	N	P	P1		PJ+
													NPT	BSP	
32	18	32	10	75	65	86	8	32,5	24	51	14	32,5	1/4"	1/4"	38
40	22	40	10	85	75	98,5	10	37,5	27	57	17	37,5	1/4"	1/4"	44,5
50	28	50	10	100	87	106,5	10	43,5	34	68	20	43,5	1/4"	1/4"	38,5
63	36	63	13	120	102	108,5	10	52	35	90	22	50	1/4"	1/4"	38,5
80	36	70	13	150	125	122	20	65	44	105	25	60	3/8"	3/8"	34
100	45	90	13	170	145	130	20	75	47	124	30	70	3/8"	3/8"	36

ØX = Bore Alesaggio ØY = Rod Stelo Z = Stroke Corsa

Choice of **OIL PORTS** type and position Determinazione degli **ORIFIZI** tipo e posizione

Example of order code:
Esempio di codice ordine:

CC	050	E	O	E			250,0	X0099,0
----	-----	---	----------	----------	--	--	-------	---------

O Manifold oil delivery
Integrati con O-Rings

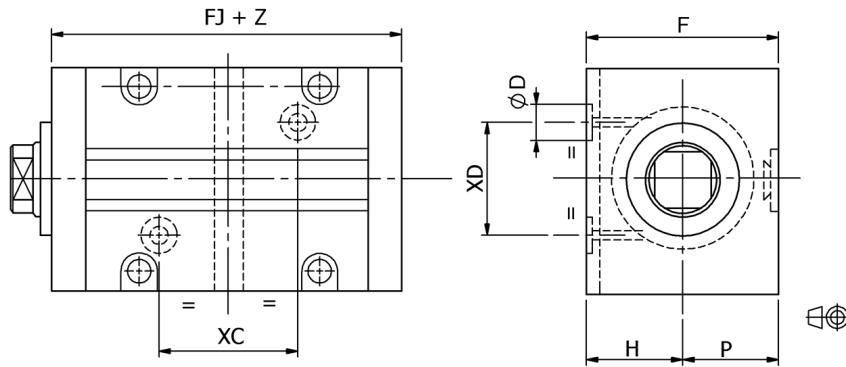

Bottom side
only for clamping E
Lato Inferiore
solo per fissaggio E

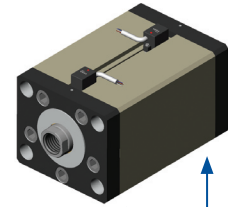

V220CC

E

O Manifold oil delivery
Integrati con O-Rings

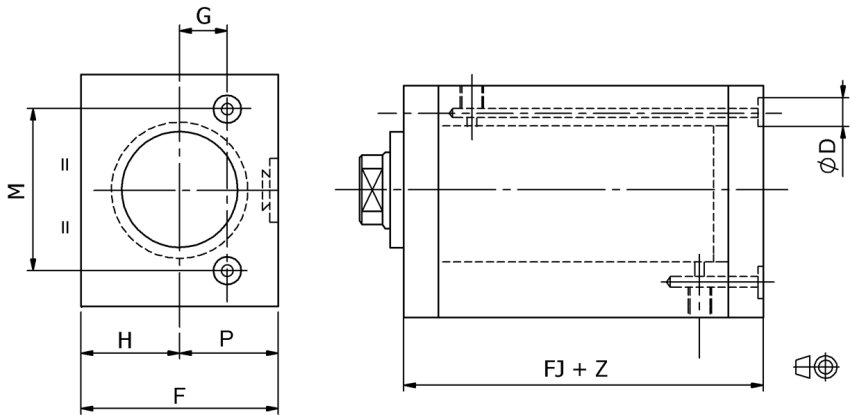

R Rear side
only for clamping B, C and F
Lato Posteriore
solo per fissaggio B, C e F

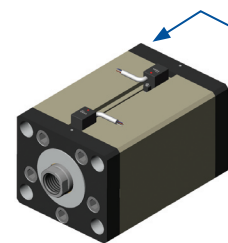

NOTES FOR MANIFOLD OIL DELIVERY: Max. bore of the oil delivery hole in the mold: 4,5 mm. for cylinder bore 32 to 50; 6 mm. for other cyl. bore. Max. eccentricity 0,5 mm. FKM O-Rings are included.

NOTE PER ORIFIZI CON O-RINGS: Diametro max. del foro di alimentazione da eseguire nello stampo: 4,5 mm. per alesaggio cilindro da 32 a 50; 6 mm. per gli altri. Eccentricità max. 0,5 mm. Gli O-Ring in FKM sono inclusi nella fornitura.

ØX	ØY	ØB	ØD	E	F	FJ+	G	H	M	P	XC	XD
32	18	32	10	75	65	86	8	32,5	51	32,5	30	36
40	22	40	10	85	75	98,5	10	37,5	57	37,5	35	40
50	28	50	10	100	87	106,5	10	43,5	68	43,5	40	46
63	36	63	13	120	102	108,5	10	52	90	50	40	50
80	36	70	13	150	125	122	20	65	105	60	45	70
100	45	90	13	170	145	130	20	75	124	70	45	80

ØX = Bore Alesaggio ØY = Rod Stelo Z = Stroke Corsa

Choice of **Rod End Style** - Determinazione del **terminale dello stelo**

Example of order code:
Esempio di codice ordine:

CC	050	E	G	H	G		250,0	X0099,0
----	-----	---	---	---	----------	--	-------	---------

DESCRIPTION OF ROD END STYLE DESCRIZIONE TIPO DI ESTREMITA'	
METRIC FEMALE thread Filetto FEMMINA METRICO	G
METRIC MALE thread Filetto MASCHIO METRICO	A
FLOATING JOINT (not for rod diam. 90, 110 and 140 mm.) TESTA A MARTELLO (non per steli diam. 90, 110 e 140 mm.)	F
UNF-UNEF female thread (U.S.A. Standard) Filetto FEMMINA UNF-UNEF (Standard U.S.A.)	I
UNF-UNEF male thread (U.S.A. Standard) Filetto MASCHIO UNF-UNEF (Standard U.S.A.)	H

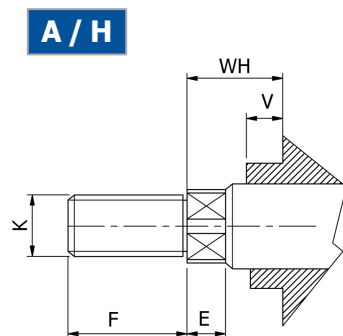

G / I

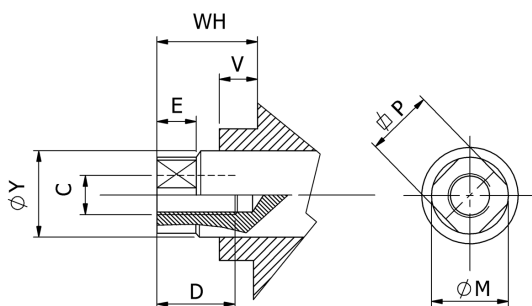

F

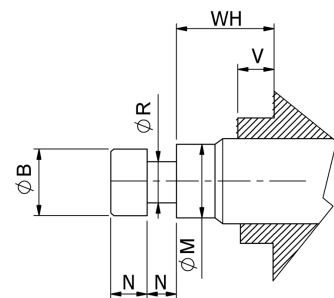

NOTES: The end and the length of the rod can be supplied differently from the options shown in this catalogue. In such a case, the customer should specify the code "S" (special) when placing the order and forward the required dimensions of the rod accompanied by a sketch. Once a clamping style is chosen, it is important to make the most suitable assessment between the piston rod and the part to be actuated. This is due to the fact that technical and practical requirements (such as inclined planes, die pins, die cheeks, extractor carriages, etc.) frequently make it impossible to achieve a correct alignment between the piston rod movement axis and the actuated mechanical part. A simple corrective system is to fit a floating joint rod end "F" which, unlike a threaded attachment system, allows a radial clearance between the rod and the moving part. As an alternative, you might use a floating joint on the female thread "G"; in such a case, see the page concerning the ACCESSORIES.

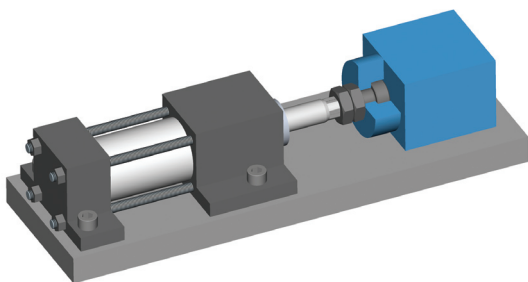

NOTE: L'estremità e la lunghezza dello stelo possono essere forniti diversi da quanto proposto dal presente catalogo. In tal caso al momento dell'ordinazione, si dovrà specificare la codifica "S" (speciale) e inoltrare le dimensioni accompagnate da uno schizzo. Scelto un fissaggio bisognerà sempre valutare attentamente l'ancoraggio più idoneo fra stelo e pezzo da movimentare. Si riscontra infatti molto spesso che necessità tecnico-pratiche (es. piani inclinati, spine, guance di stampi, carrelli di estrazione, ecc.) non permettono un corretto allineamento tra l'asse di traslazione dello stelo e l'organo comandato. Un semplice sistema correttivo è dato dall'applicazione della testa a martello "F" che, diversamente dall'ancoraggio con filetto, consente un gioco radiale tra stelo ed organo in movimento. In alternativa è possibile una testa a martello riportata sul filetto femmina "G"; in tal caso vedere catalogo ACCESSORI.

ØX	ØY	ØB	C		D	E	F	ØM	N	K		ØP	ØR	V	WH
			METRIC	UNF-UNEF						METRIC	UNF-UNEF				
32	18	32	M10×1,5	3/8-24	20	6	18	17	7	M14×1,5	9/16-18	15	10	2	10
40	22	40	M12×1,75	1/2-20	20	8	22	21	8	M16×1,5	1/2-20	18	11	2	11,5
50	28	50	M20×2,5	3/4-16	30	8	28	27	10	M20×1,5	3/4-16	24	14	2	13
63	36	63	M27×3	1/12	40	11	36	35	12.5	M27×2	1/12	32	18	2	15
80	36	70	M27×3	1/12	40	11	36	35	12.5	M27×2	1/12	32	18	2	15
100	45	90	M33×3,5	1-1/4-12	50	12	45	44	16	M33×2	1-1/4-12	40	22	2	21

ØX = Bore Alesaggio ØY = Rod Stelo Z = Stroke Corsa

Choice of **Cylinder VERSION** - Determinazione della **VERSIONE del cilindro**

Example of order code:
Esempio di codice ordine:

CC	050	E	O	E	G	M	250,0	X0099,0
----	-----	---	---	---	---	----------	-------	---------

DESCRIPTION - DESCRIZIONE	
Cylinder WITH MAGNETIC PRESET (switches not included) <i>Cilindro CON PREDISPOSIZIONE MAGNETICA (sensori non inclusi)</i>	M
Cylinder WITHOUT magnetic preset. <i>Cilindro SENZA predisposizione magnetica.</i>	N
Cylinder WITHOUT Switch Key <i>Cilindro SENZA Cava Sensori</i>	W

MAGNETIC SWITCHES (ONLY FOR "M" VERSION; usually two for cylinder) SENSORI MAGNETICI di fine corsa (SOLO PER VERSIONE "M"; solitamente due per cilindro)

Example of order code:
Esempio di codice ordine:

MSU4

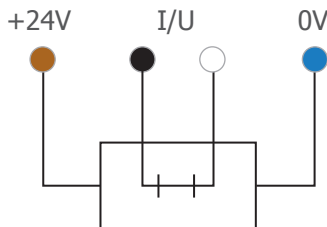

Wire Colour / Colore Conduttori

- Brown Marrone = +24V DC
- Blue Blu = 0V DC
- Black Nero = In/Out Contact Contatto In/Out
- White Bianco = In/Out Contact Contatto In/Out

I/U = In/Out In/Out

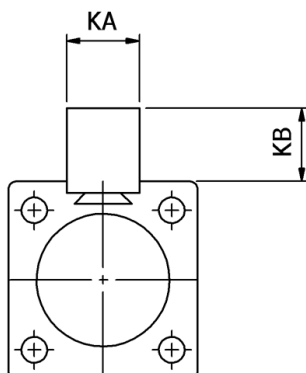

Switches Technical Data MSU4 Dati tecnici sensori MSU4	
Supply - Alimentazione	24 VDC ± 10%
Protection - Protezione	polarity inversion <i>inversione di polarità</i>
Output - Tipo di segnale	clean contact 0V <i>contatto pulito 0V</i>
Max. switching voltage - Tensione Max. commutabile	125 VAC
Max. switching current <i>Corrente Max. commutabile</i>	800 mA
Max. switching frequency <i>Frequenza max. di commutazione</i>	60 Hz
Max. switching power - Potenza Max. commutabile	20 W
Electric life at rated power (operations) <i>Vita elettrica</i>	10,000,000
Hysteresis - Isteresi	±0,02 mm typical - <i>tipico ±0,02 mm</i>
24 volt disconnection delay <i>Ritardo alla disinserzione a 24v</i>	15 m sec.
Max. working temperature <i>Temperatura Max. di esercizio</i>	+80° C - +176° F
Cable (Extraflex armoured + transp. PVC sheath) <i>Cavo (corazzato Extraflex + guaina PVC trasp.) mm</i>	Ø6 x 3000
Section wires - Sezione conduttori	4x0,25 mm ²
Serial signal connection <i>Collegamento del segnale in serie</i>	ok, max 6 switches <i>si, max 6 sensori</i>
Switch type - Tipo di sensore	electronic, magnet-resistive <i>elettronico magnetosensitivo</i>
Repeatability - Ripetibilità	> 0,05 mm.
ON minimum time - Tempo minimo in ON	3 msec.
Max. flow speed - Velocità max. di passaggio	15 mt/sec.
Degree of protection against liquids <i>Grado di protezione ai liquidi</i>	IP 67 (DIN 40050)
Dimensions - Dimensioni mm	39x24x28

ØX	KA	KB
32	22	20
40		20
50		20
63		25.5
80		25.5
100		25.5

ØX = Bore Alesaggio



Rod accessories for rod Metric or UNF thread

Accessori stelo per estremità filetto stelo Metrico o UNF

Example of order code:
Esempio di codice ordine:

MTA 10X150

METRIC (G)	UNF-UNEF (I)	ØX	ØY	#1	
10X150	3/8-24	32	18	G	I
12X175	1/2-20	40	22	G	I
20X250	3/4-16	50	28	G	I
27X300	1-12	63	36	G	I
27X300	1-12	80	36	G	I
33X350	1-1/4-12	100	45	G	I

#1 : Compatible rod end code
Cod. estremità stelo compatibile

V220CC

MTA



Metric Male Thread
Filetto maschio metrico

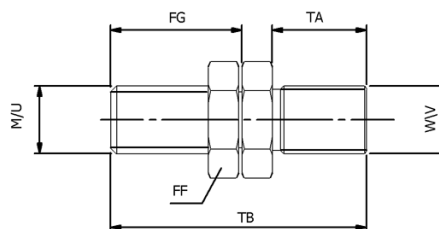

MFA



Floating Joint
Testa a martello

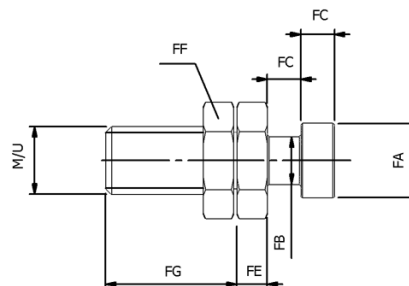

DFA

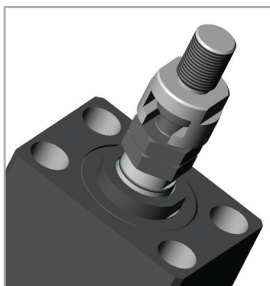

Floating Joint With Female
Testa a martello con femmina

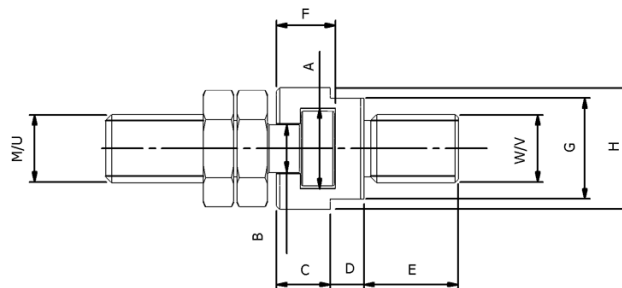

		METRIC		UNF-UNEF		A	B	C	D	E	F	G	H	FA	FB	FC	FE	FF	FG	TA	TB
		M	W	U	V																
10X150	3/8-24	M10×1,5	M10×1,25	3/8-24	3/8-24	17,5	11	11	8	16	12,5	21	25	16	10	7	6	17	24	14	44
12X175	1/2-20	M12×1,75	M12×1,25	1/2-20	1/2-20	19,5	12	13	9	18	14,5	24	28	18	11	8	7	19	28	16	51
20X250	3/4-16	M20×2,5	M20×1,5	3/4-16	3/4-16	24	15	16	10	28	17,5	30	36	22	14	10	9	30	39	28	76
27X300	1-12	M27×3	M27×2	1-12	1-12	30	19	20	12	40	23	36	44	28	18	12,5	12	36	52	36	100
33X350	1-1/4-12	M33×3,5	M33×2	1-1/4-12	1-5/16-18	39	23	23	14	50	27,5	46	55	35	22	16	14	46	64	45	123

ØX = Bore Alesaggio ØY = Rod Stelo Z = Stroke Corsa

Spare Parts - Ricambi

1. Magnetic switch - *Sensore magnetico*
2. Piston seals kit - *Kit guarnizioni pistone*
3. Magnet ring - *Anello magnetico*
4. Piston - *Pistone*.
5. Body - *Corpo*.
6. Rod - *Stelo*.
7. Rod seals kit - *Kit guarnizioni stelo*.

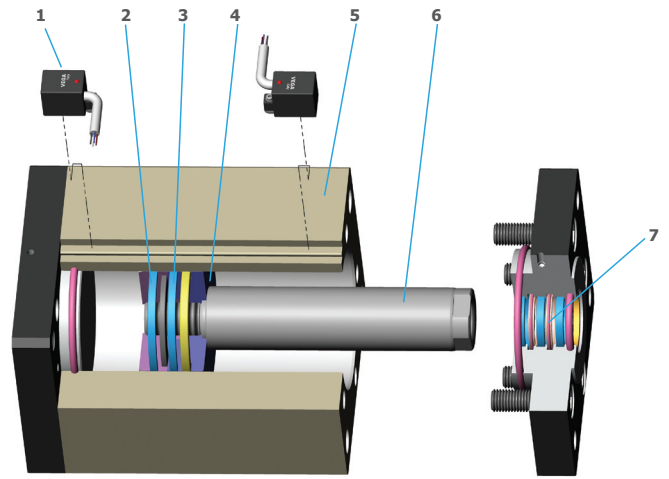

Type	Cylinder bore	Article Code	Ports position	Additional set code	Cylinder stroke	X quote	Description	Quantity
RC	6010	A					Rod seals kit - <i>Serie guarnizioni stelo</i>	7
RC	6020	A					Piston seals kit - <i>Serie guarnizioni pistone</i>	2
RC	6050						Permanent magnet ring - <i>magnete permanente</i>	3
RC	6030						Manifold oil delivery FKM O-rings - <i>O-rings per alimentazione olio integrata</i>	-
RC	1510	A					Magnetic piston with seals - <i>Pistone magnetico con guarnizioni</i>	2 + 3 + 4
RC	1520	A					Non-magnetic piston with seals - <i>Pistone non magnetico con guarnizioni</i>	2 + 4
RC	... 1911				Body for Clamping "B", NPT threaded ports - <i>Corpo fissaggio "B" orifizi fil. NPT</i>	5
RC	... 1912				Body for Clamping "B", manifold ports - <i>Corpo fissaggio "B" orifizi integrati con OR</i>	
RC	... 1920				Body for Clamping "C", BSP threaded ports - <i>Corpo fissaggio "C" orifizi fil. BSP</i>	
RC	... 1921				Body for Clamping "C", NPT threaded ports - <i>Corpo fissaggio "C" orifizi fil. NPT</i>	
RC	... 1922				Body for Clamping "C", manifold ports - <i>Corpo fissaggio "C" orifizi integrati con OR</i>	
RC	... 1940				Body for Clamping "E", BSP threaded ports - <i>Corpo fissaggio "E" orifizi fil. BSP</i>	
RC	... 1941				Body for Clamping "E", NPT threaded ports - <i>Corpo fissaggio "E" orifizi fil. NPT</i>	
RC	... 1930				Body for Clamping "E", manifold ports - <i>Corpo fissaggio "E" orifizi integrati con OR</i>	
RC	... 1960				Body for clamping "B", BSP threaded ports version "W" - <i>Corpo fissaggio "B" orifizi fil. BSP Versione "W"</i>	
RC	... 1961				Body for clamping "B", NPT threaded ports version "W" - <i>Corpo fissaggio "B" orifizi fil. NPT Versione "W"</i>	
RC	... 1962				Body for clamping "B", manifold ports version "W" - <i>Corpo fissaggio "B" orifizi integrati con OR Versione "W"</i>	
RC	... 1970				Body for clamping "C", BSP threaded ports version "W" - <i>Corpo fissaggio "C" orifizi fil. BSP Versione "W"</i>	
RC	... 1971				Body for clamping "C", NPT threaded ports version "W" - <i>Corpo fissaggio "C" orifizi fil. NPT Versione "W"</i>	
RC	... 1972				Body for clamping "C", manifold ports version "W" - <i>Corpo fissaggio "C" orifizi integrati con OR Versione "W"</i>	
RC	... 1990				Body for clamping "E", BSP threaded ports version "W" - <i>Corpo fissaggio "E" orifizi fil. BSP Versione "W"</i>	
RC	... 1991				Body for clamping "E", NPT threaded ports version "W" - <i>Corpo fissaggio "E" orifizi fil. NPT Versione "W"</i>	
RC	... 1980				Body for clamping "E", manifold ports version "W" - <i>Corpo fissaggio "E" orifizi integrati con OR Versione "W"</i>	

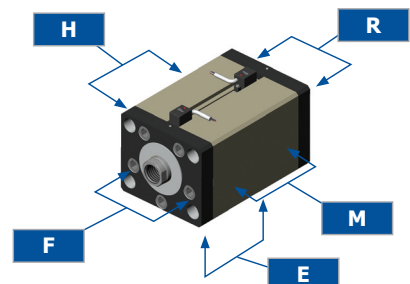

Example of order code:
Esempio di codice ordine:



RC	...	1120	1122		...	Rod with rod end style "G" - Stelo con terminale "G"	6
RC	...	1121	1123		...	Rod with rod end style "I" - Stelo con terminale "I"	
RC	...	1110	1112		...	Rod with rod end style "A" - Stelo con terminale "A"	
RC	...	1111	1113		...	Rod with rod end style "H" - Stelo con terminale "H"	
RC	...	1130	1131		...	Rod with rod end style "F" - Stelo con terminale "F"	
RC	...	1550	1552	A	...	Magnetic rod-piston group with rod end style "G" Stelo-pistone magnetico con terminale "G"	2+3+4+6
RC	...	1551	1553	A	...	Magnetic rod-piston group with rod end style "I" Stelo-pistone magnetico con terminale "I"	
RC	...	1530	1532	A	...	Magnetic rod-piston group with rod end style « A » Stelo-pistone magnetico con terminale "A"	
RC	...	1531	1533	A	...	Magnetic rod-piston group with rod end style "H" Stelo-pistone magnetico con terminale "H"	
RC	...	1570	1571	A	...	Magnetic rod-piston group with rod end style "F" Stelo-pistone magnetico con terminale "F"	
RC	...	1560	1562	A	...	Non magnetic rod-piston group with rod end style "G" Stelo-pistone non magnetico con terminale "G"	2+4+6
RC	...	1561	1563	A	...	Non magnetic rod-piston group with rod end style « I » Stelo-pistone non magnetico con terminale "I"	
RC	...	1540	1542	A	...	Non magnetic rod-piston group with rod end style "A" Stelo-pistone non magnetico con terminale "A"	
RC	...	1541	1543	A	...	Non magnetic rod-piston group with rod end style "H" Stelo-pistone non magnetico con terminale "H"	
RC	...	1580	1581	A	...	Non magnetic rod-piston group with rod end style "F" Stelo-pistone non magnetico con terminale "F"	

Rods for cylinder with CLAMPING "F", front flange
 Steli per cilindro con FISSAGGIO "F", flangia anteriore
 Rods for cylinder with all CLAMPINGS, except front flange "F"
 Steli per cilindro con tutti i FISSAGGI eccetto flangia anteriore "F"

MSU4	Magnetic switch with fixing bracket - Sensore magnetico con staffa	1
-------------	--	---



www.vegacylinder.com